

Removing and installing coolant pump

Removing

- Remove poly V-belt → [Chapter](#).
- Remove poly V-belt tensioner -arrows-.
- Remove toothed belt from camshaft sprocket → [Chapter](#).
- Drain off coolant → [Chapter](#).
- Remove centre section of toothed belt cover → [Item](#).



Note

t Vibration damper and bottom section of toothed belt cover can remain installed.

t The toothed belt should be left in position on the crankshaft sprocket.

t Before removing coolant pump, cover toothed belt with a cloth to protect against coolant.

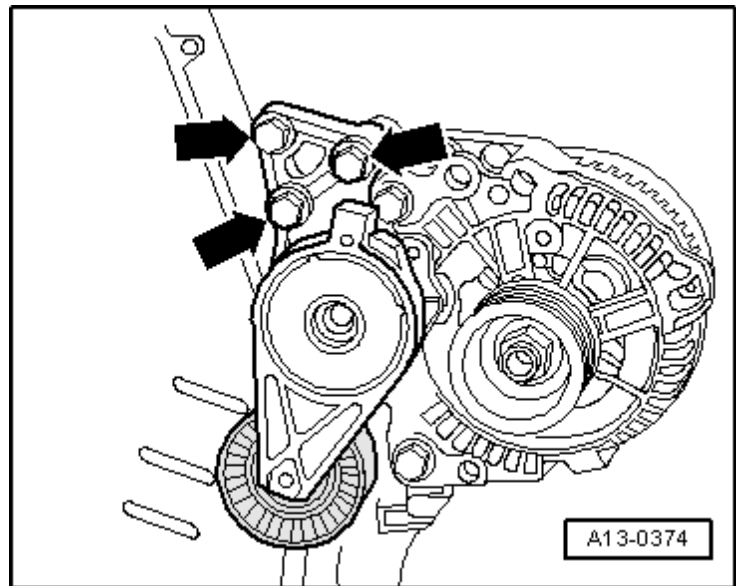

- Remove bolts -1- and detach coolant pump -2-.

Installing

Installation is carried out in the reverse order; note the following:



Note

Renew seals and gaskets.

- Clean and smoothen sealing surface for O-ring as required.

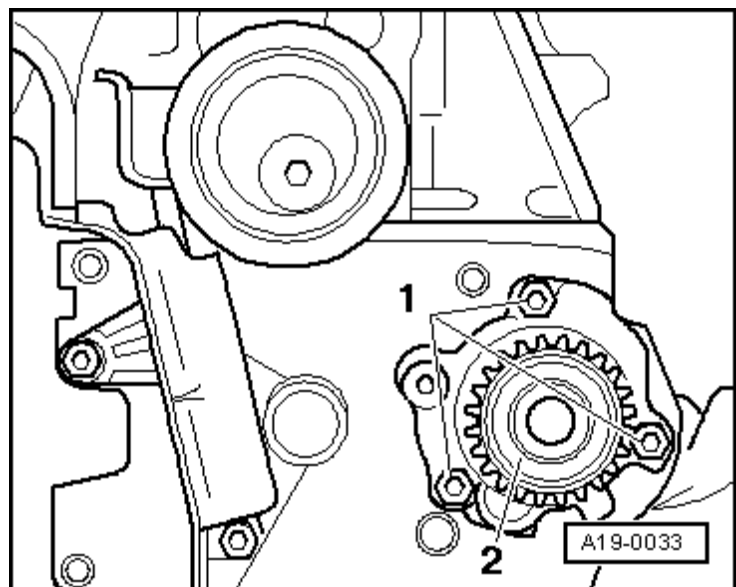

- Lubricate new O-ring -3- with coolant additive "G12+".

- Fit coolant pump -2-.

1 Sealing plug in housing faces downwards.

- Tighten bolts -1- for coolant pump.
- Install toothed belt (adjust valve timing) → [Anchor](#).
- Install poly V-belt → [Chapter](#).
- Fill cooling system → [Anchor](#).

Tightening torques

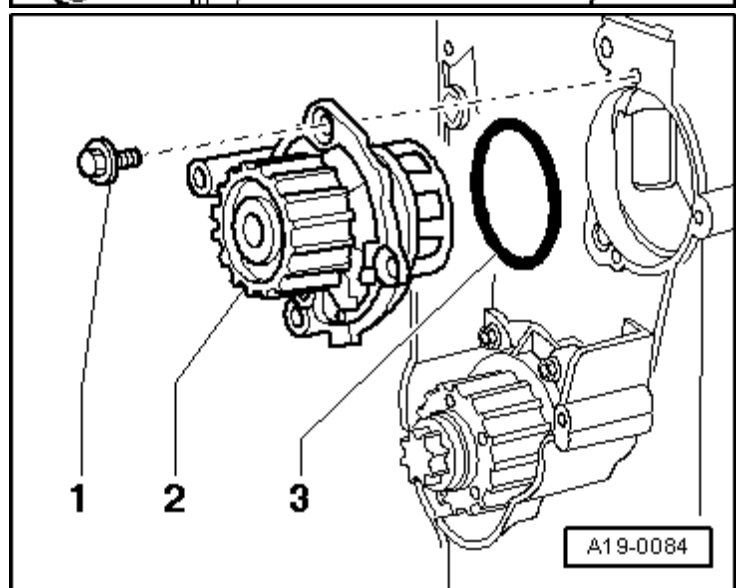

Component	Nm
Coolant pump to cylinder block	15
Toothed belt cover (centre) to cylinder block	10 ¹⁾
Tensioner for poly V-belt to bracket for ancillaries	23
1 ¹⁾ Install using locking fluid; for locking fluid refer to → Parts catalogue .	